

The MotionMonitor xGen Hardware Guide: Interface to Ascension trakSTAR

Shown below are the main components for an Ascension trakSTAR system with USB interface. Components of note include a transmitter, sensors and trakSTAR electronics unit.

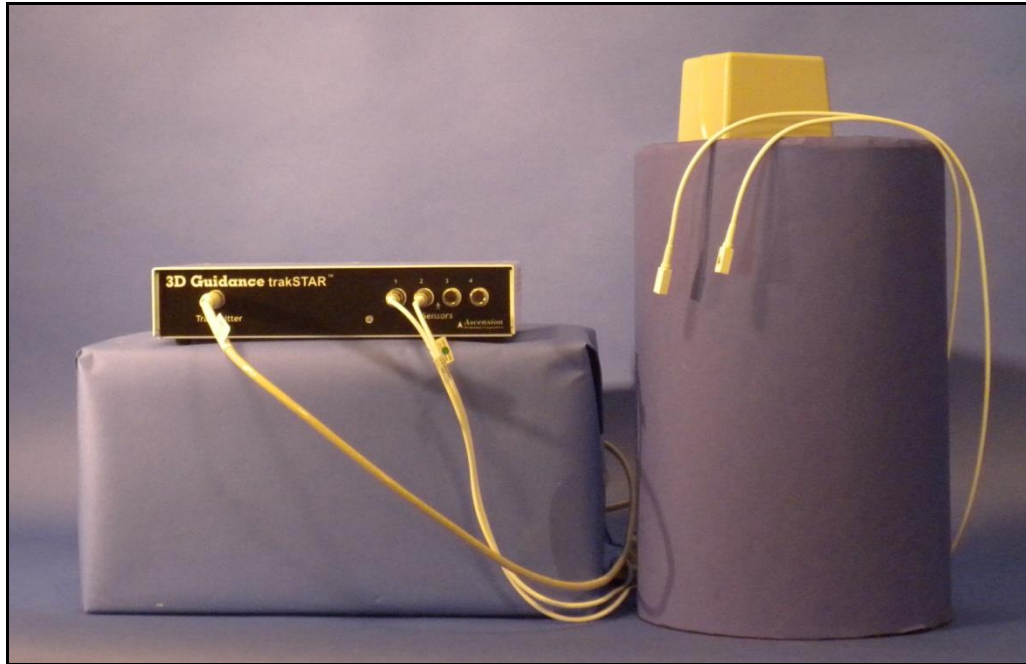

The following images are meant to be used as a guide for the setup of your trakSTAR system. The images and text to follow may also become helpful if the need for troubleshooting should ever arise.

The following image depicts the trakSTAR front panel. This is where the transmitter and sensor cable connections are located. The trakSTAR indicator light can also be found on the front panel. The indicator light will be solid green when the sensors have been successfully activated and should blink green when waiting for a connection.



The next image depicts the trakSTAR back panel. This is where the power and USB cable connections are located, as well as the on/off switch for the electronics unit. The unit synch connection allows for multiple trakSTAR electronics units to be synchronized, while the Switch connection allows for the input of an external trigger.



The installation of drivers will need to be performed on every USB port, for each USB port to support the trakSTAR electronics unit. During setup, you may be prompted to complete this step on a single USB port multiple times. After installing the drivers on each USB port, try disconnecting and re-connecting the USB cable again to ensure that the device is properly recognized. Once the driver installation process is completed, the system is ready to be used. Please contact your [Client Support Engineer](#) if you encounter any issues with installing your trakSTAR drivers.

However, before collecting any data, each trakSTAR electronics unit must be configured using the trakSTAR Utility program. This program should have been installed, along with the cubes program, from your Ascension installation cd and can be found at the following path after installation: C:\Program Files\Ascension. Anytime you run the trakSTAR Utility program on a computer with multiple trakSTAR electronics units, only one electronics unit should be powered on at a time. Begin with the electronics unit that will be connected to the transmitter, this will be your master unit. Then, continue to your first slave electronics unit and so on. Sensors 1-4 will be connected to your master device, 5-8 to your 1st slave device, etc. Select USB from the “Media” type drop-down menu in the interface configuration window, as seen below. Then, select the “Unit” number from the drop down menu. The master will be set to zero, the 1st slave set to 1, the 2nd slave set to 2 and so on. The first time you run the trakSTAR Utility with each electronics unit, the Unit values may not be available or may be set to zero by default. Click “Connect” to continue.

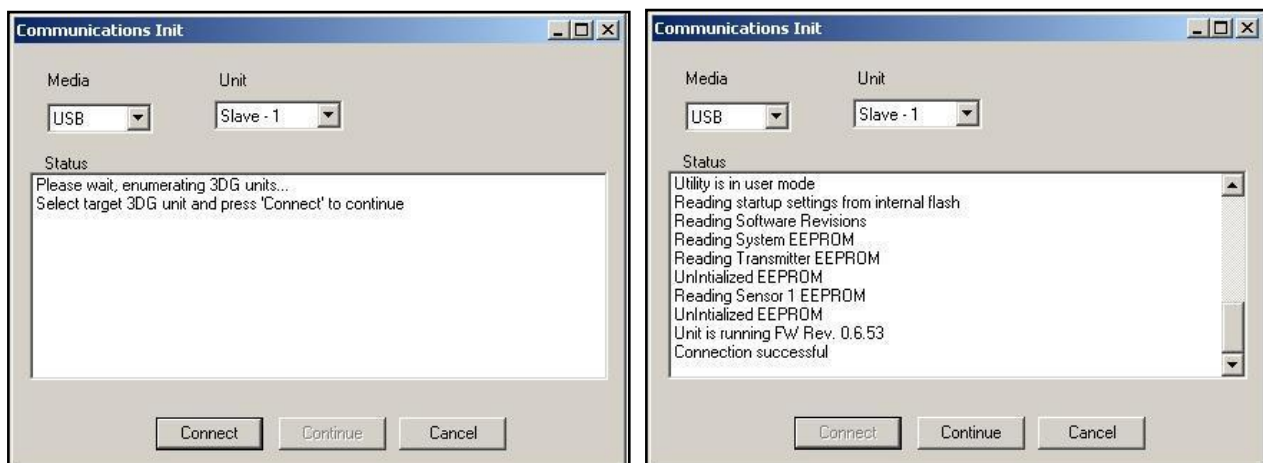

Once you’ve established a successful connection, click “Continue” to open the trakSTAR utility window.

For each electronics unit, change the Report value to 3 and set the “MultiUnit ID” appropriately (keep all other default settings). Again, the “Multiunit ID” for the master electronics unit should be 0, the 1st

slave electronics unit (sensors 5-8) should be set to 1, and so on. Then, click “Apply” and close the application. After completing this process for each electronics unit perform a power cycle for your entire system, including the electronics units and computer.

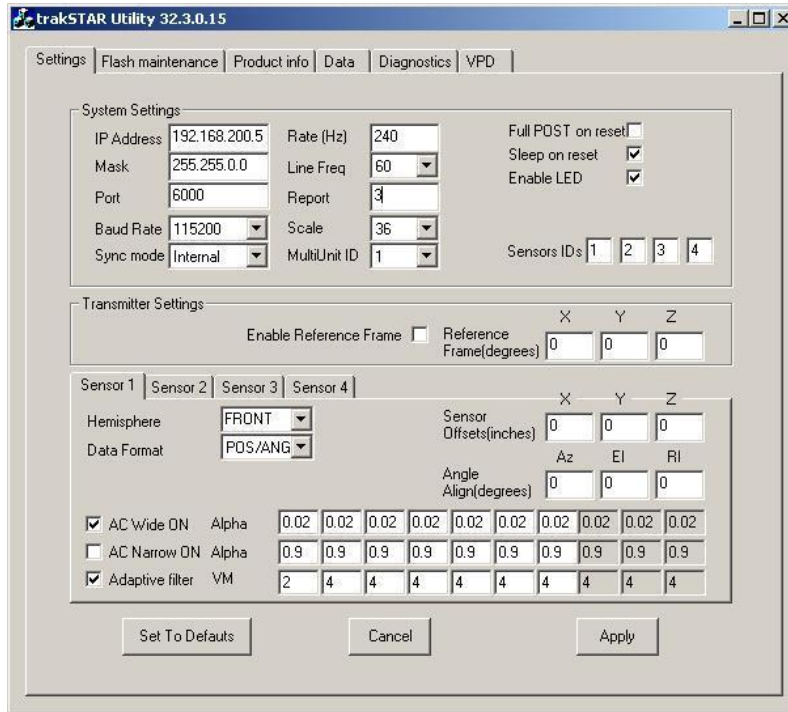

You are now ready to run your trakSTAR system with The MotionMonitor xGen.

1. Start The MotionMonitor xGen and go to the Hardware node in the Setup Components window. Add the Ascension device from the Add button in the parameters panel at the bottom of the Components window or by right clicking the Hardware node and adding the device through the cascading drop list.

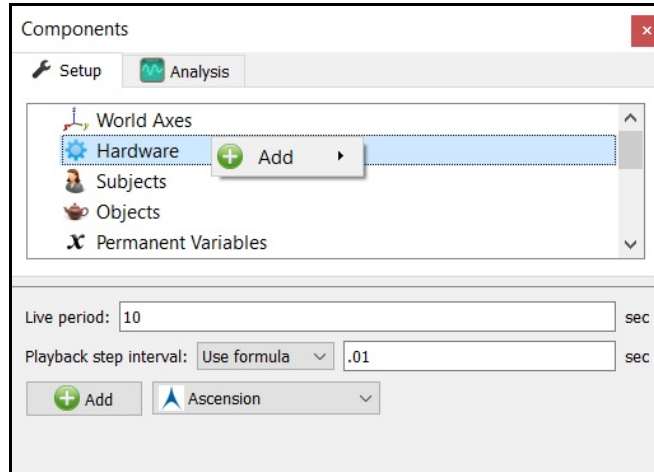

2. Click on the Ascension device to bring up the Ascension parameters panel. Specify the name and transmitter type, based on the transmitter type used, either standard range transmitter (36" or 72") or wide area transmitter (144" or 288"). Set the Report rate (valid settings include integers between 3-10, the default rate is 3) and Measurement rate (20-250 frames/sec).

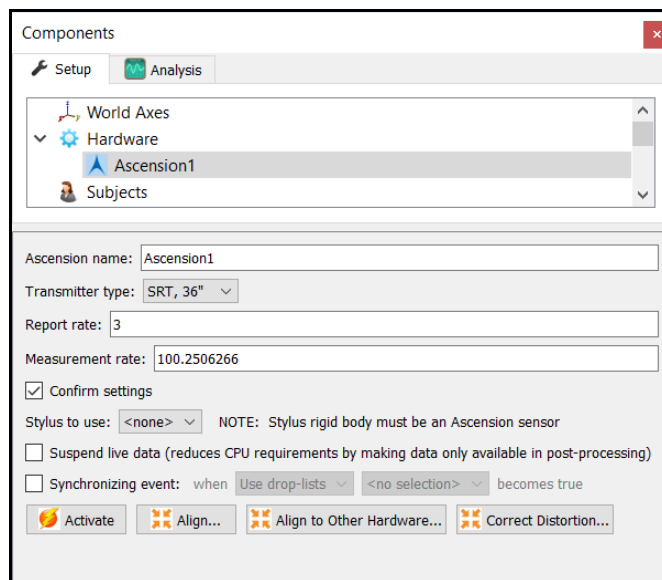

The "Confirm settings" check box will send a command to the hardware to verify the settings from the device.

You will notice that the value in the measurement rate field will update after entering an integer and clicking away from the edit field. This process is normal and ensures synchronous data collection with other data sources, as the actual measurement rate of the trakSTAR is slightly different from the specified integer. Similarly, the setting in the Report Rate field may automatically update the Measurement Rate. The Report Rate is the measurement rate divisor, so as it is increased, the maximum Measurement Rate of the system will decrease. Increasing the Report Rate provides the ability to expand the capture volume of the system by increasing the amount of time between readings and reducing the impact that distortion may have. With a report rate of 3, the system can run at its maximum Measurement Rate of 240 Hz. The MotionMonitor will automatically update the Measurement Rate field with the highest rate available for a given Report Rate. Typically, the Report Rate should not be modified, unless advised by your Client Support Engineer.

The stylus that is being used for aligning this hardware device (i.e. digitizing a new world axes, unique from the default transmitter coordinate system) must be selected here for the Stylus to use. After Activating the hardware, the “Align” button will result in a sequence of prompts for digitizing a new world axes layout according to the selections for the World Axes layout in the World Axes Setup Component.

The default transmitter reference frame is depicted below. Readings from the sensors can only be accurately taken from the front (positive X) hemisphere.

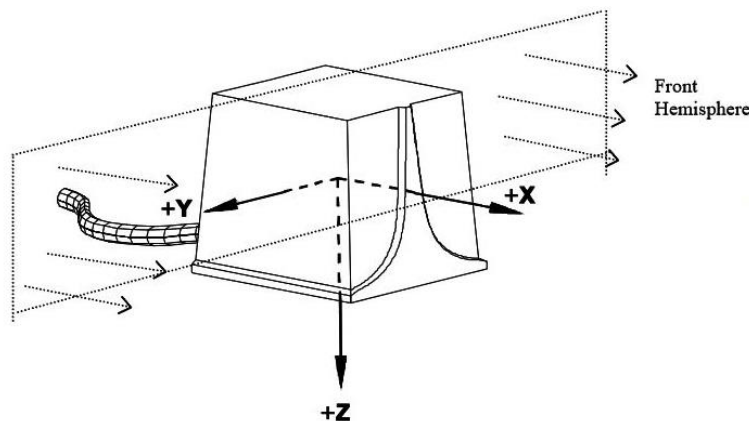

Data in the Live window can be suspended by placing a mark in the checkbox for Suspend live data. The processing and display of data in a live mode uses computer resources, so this option allows the user to optimize computer resources and free up more processing power for data collection. This setting is independent for each hardware device and once an activity has been recorded data from the full measurement rate will be accessible for analysis.

A synchronizing Boolean event can be specified for performing an active alignment of the Ascension data stream with synchronous events from other hardware data streams. The Synchronizing event used here must be defined from Ascension data (i.e. the electronics unit switch input, which could be defined as *Ascension1.Sensor1.Event=1*, if the synchronizing event were connected to the Switch Input on the Master TrakSTAR electronics unit).

The Align to other hardware and Correct distortion buttons are advanced features for hybrid configurations and for performing metal mappings, respectively. Please contact your [Client Support Engineer](#) for more information regarding these processes.

The “Activate” button will initialize the communication between The MotionMonitor xGen and Ascension hardware.

- Expand the Ascension node to show the detected sensors. Selecting a Sensor brings up the Sensor parameter panel. Smoothing settings can be enabled or disabled here, pre or post data collection.

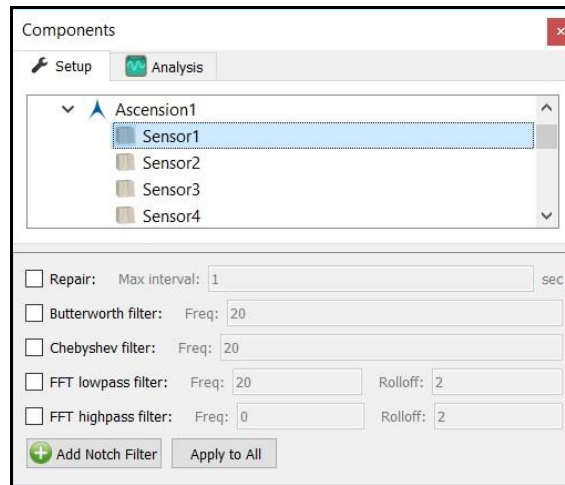

- After all these parameters have been configured the Ascension hardware device can be activated from the Ascension parameters panel. Click the “Activate” button to initialize the communication between The MotionMonitor xGen and Ascension hardware.
- A Stylus will need to be configured for digitizing the alignment of the Ascension hardware device, force plates and defining joint centers or other landmarks of interest for your subject. From the Hardware node in the Setup Components window add the Stylus device from the Add button in the parameters panel at the bottom of the Components window or by right clicking the Hardware node and adding the device through the cascading drop list.

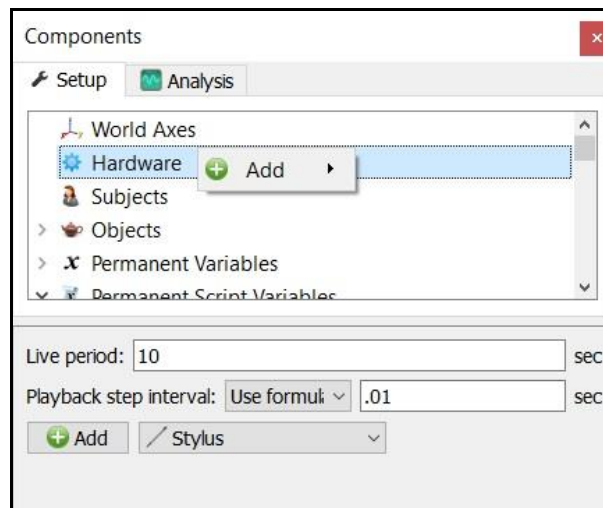

- Click on the Stylus device to bring up the Stylus parameters panel. Specify the name and Rigid body affixed to the stylus. An Is-button-pressed expression is a Boolean value that allows for an external trigger to be used in the OK messages where the stylus is being used in the setup, such as when performing the alignment of a hardware device, aligning force plates or when digitizing a subject. The Rigid body is at stylus tip checkbox can be enabled when the origin of the Rigid body specified for the stylus is already located at the tip for the stylus being used. The Calibrate button walks through the procedure of calculating the vector offset from the Rigid body origin to the stylus tip or captures the orientation of the stylus if the Rigid Body is at stylus tip is selected. A tutorial video for configuring and calibrating a stylus can be found at <https://themotionmonitor.com/support/>.

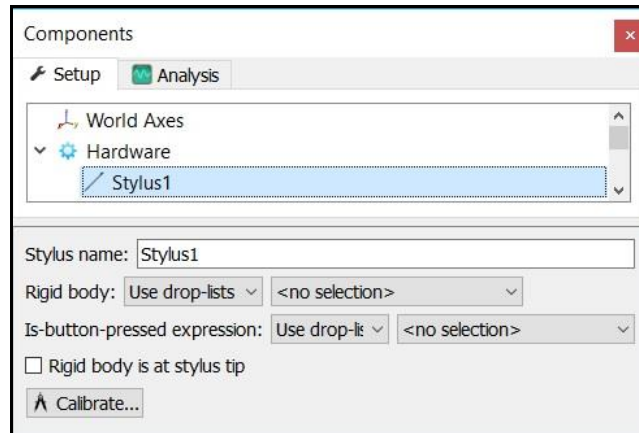

- The next step is to define your biomechanical model within **The MotionMonitor xGen**, which entails selecting which body segments you'll be tracking, assigning rigid bodies to track each body segment, defining segment endpoints or joint centers and generating customized segment axes, if desirable. To begin this process, right click on the Subjects header within the Components Setup tab and add a new subject by clicking on the "Add Subject" button in the Subjects parameters panel or right clicking on the Subjects node and selecting Add Subject.

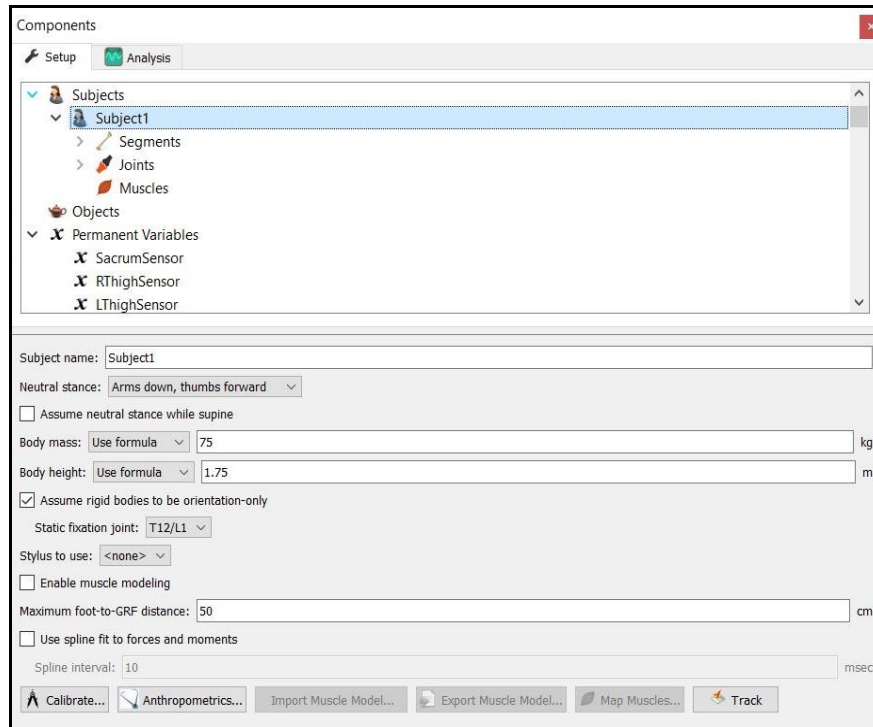

As seen above, a name can be assigned to the subject and basic anthropometric data can be entered. Confirmation for the orientation of the subject during the static reading and selection of a stylus to be used for digitizing, if required, are also selected here. The Calibrate button can be clicked after all of the required setup information has been entered.

- The Segments header located under the Subject node is where the desired segments to be tracked can be enabled as well as where the assignment for which rigid body will be used to track the segment is defined. Additional basic anthropometric information can be defined here for each segment as well.

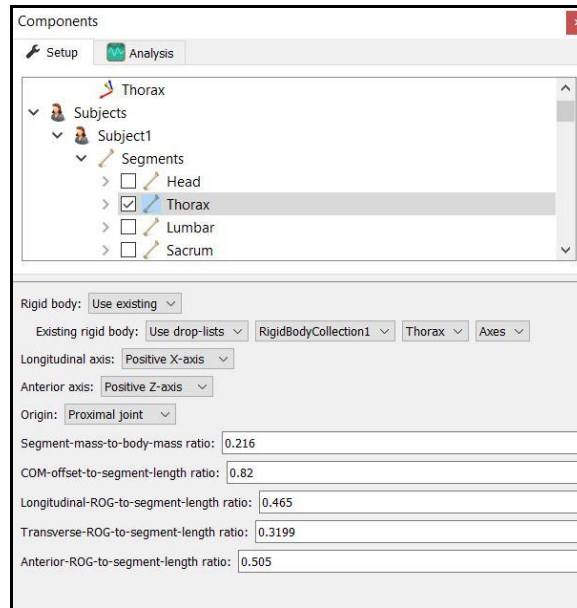

- Each body segment which is enabled will require the definition of a proximal and distal endpoint or joint centers. The required joint centers will be automatically populated based on the selection of segments.

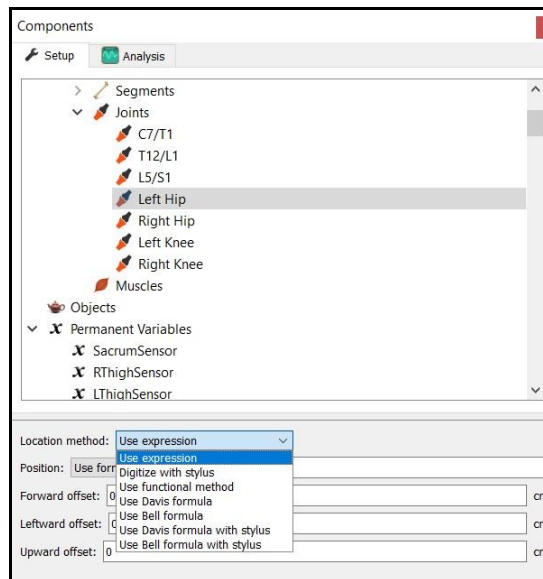

- As seen above, each joint center can be defined using a digitizing method or expression based on marker positions. Alternatively, the hip and shoulder joints can be defined using linear regression algorithms or functional (rotational) methods.

11. Once these definitions are completed, the Subject Calibrate button can be clicked. A warning message will be displayed for any definitions that have not been appropriately defined.
12. Additionally, if alternative or anatomically based local coordinate systems are desired, they can be defined by right clicking on a segment and selecting Add Axis System. First, the Rigid Body axes tracking the segment and general axes layout are selected. Then, points can be defined for the proximal and distal endpoints of the primary axis, a point along the secondary axis and a point for the Origin. The default local coordinate axes generated by **The MotionMonitor xGen** are defined as having a long axes through the joint centers and A/P and M/L axes being orthogonal to the long axes and parallel to the world when the subject was standing in the neutral position.

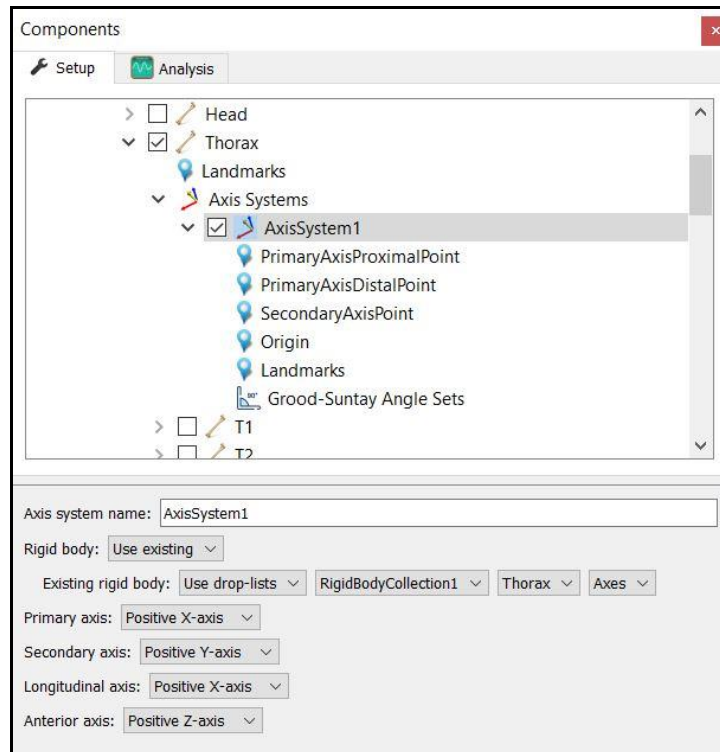

13. At this point, the **The MotionMonitor xGen** subject is fully defined and can be used for **biomechanical models, recording activities, performing computations and reducing data.**

See our “Getting Started Biomechanics Guide” for more information on these aforementioned topics. For further configuration of your software, visit <https://themotionmonitor.com/support/> where you can...

- Download The MotionMonitor xGen Elements PDF, a written manual explaining key features of the software
- Review tips for Best Practices in configuring your MotionMonitor xGen software for optimal performance
- Take a video tour of The MotionMonitor xGen basic elements.
- Review training and tutorial videos, including basic software functionalities.